

X-CALIBUR V

BEL-50

DENTAL CHAIR

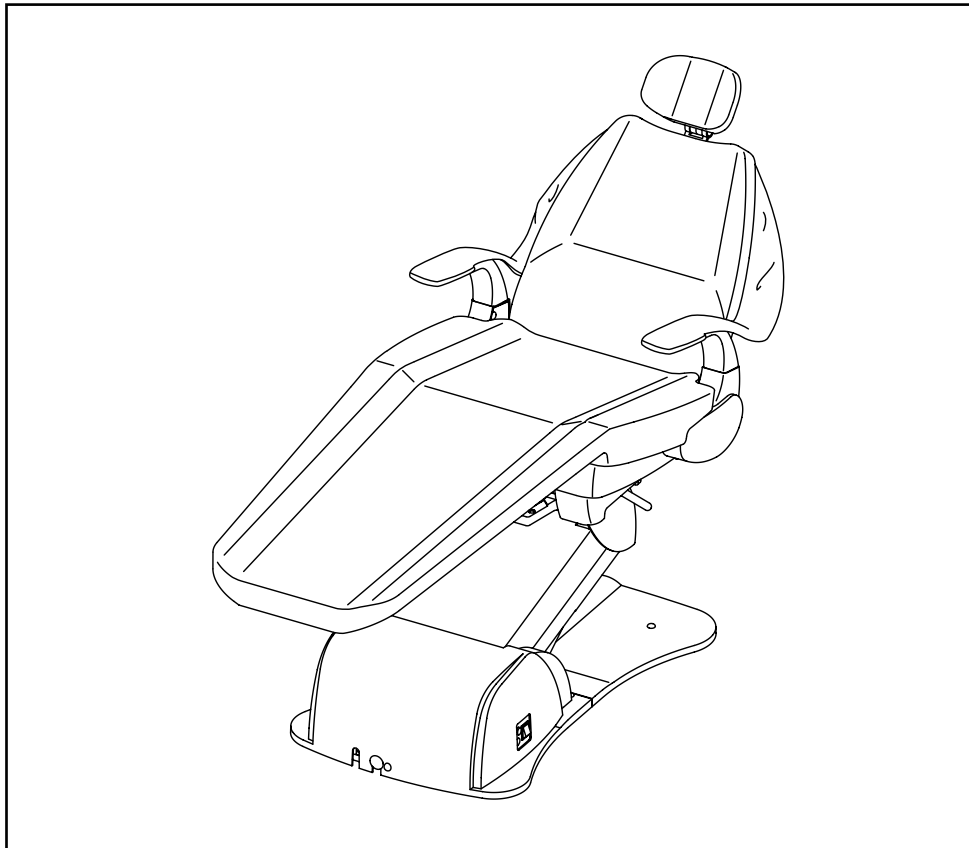

**OPERATING
INSTRUCTIONS**

IMPORTANT

This manual provides operating instructions for the BEL-50 Chair. The instructions contained in this booklet should be thoroughly read and understood before operating the chair. After the installation has been completed, keep this manual in a safe place and refer to it for future maintenance.

 **Belmont**[®]

AEFS98D0

Table of Contents

1. Overview and major components -----	1
2. Dimensions and Specifications -----	2A
3. Operations -----	3
4. Care and Maintenance -----	6

Intended Use of the Product

This product is intended for the exclusive use for diagnoses, treatments and relative procedures of dentistry, and must be operated or handled by the qualified dentists or by dental staffs under the supervision of the dentist. Such dentists or dental staffs should instruct and/or assist the patients to approach to and leave from the product. Patients should not be allowed to operate or handle the product unless he/she is so instructed.

Environmental Requirements

Operating	Ambient Temperature	41°F ~ 104°F (5°C ~ 40°C)
	Humidity	30% ~ 75%
	Atmospherical Pressure	10.2psi ~ 15.4psi (700hpa ~ 1060hpa)
Storage	Ambient Temperature	14°F ~ 122°F (-10°C ~ 50°C)
	Humidity	10% ~ 80%
	Atmospherical Pressure	8.7psi ~ 15.4psi (600hpa ~ 1060hpa)

Classification

- Protection against electric shock : Class I Equipment, Type B Applied Parts  (Headrest, Backrest and Seat cushions)
- Protection against water ingress : Chair (IPX0), Foot control (IPX1)
- Equipment not suitable for use in the presence of a flammable anesthetic mixture with air or with oxygen or nitrous oxide.
- Mode of operation : Non-continuous operation. ON time :3min. OFF time : 15 min

Symbol



Applied part complying with the specified requirements of IEC60601-1:2005 to provide protection against electrical shock, particularly regarding allowable patient leakage current and patient auxiliary current.



Caution, warning or note

 **CAUTION**

- This chair is intended to be used for dental examination and treatment. Do not use this for any other purpose than examination or treatment.
- Only a trained and qualified personnel should operate this chair.
- Follow all the safety precautions and instruction to protect patients and operators.
- During treatment keep small children, except for a patient, away from the treatment area.
- Always keep an eye on the patient so he/she shall not touch the equipment.
- Keep patient's and operator's hands, fingers or parts of the body away from moving parts of the equipment.
- In the case of defect, put a proper label on it. Call a technician of our authorized dealer.
- This product may be affected by sources that generate excessive electromagnetic waves.
- Do not install this equipment close to such devices such as elevators or communication equipment, including cellular telephones.
- Electrosurgical knives may cause the chair to temporarily malfunction. If an electrosurgical knife is to be used, turn off the main switch of the chair after the patient has been positioned.
- Take extreme care with patients that have a pacemaker. Prior to operation of the chair, ask patient to verify whether they have a pacemaker. When operating chair, be certain patient displays no indication of discomfort. Cease chair operation immediately and turn off main power switch if patient shows any sign of being affected by chair operation.
- Do not position this equipment so that it is difficult to access the main power supply outlet that the power plug of this chair is connected to.

 **CAUTION**

The followings are prohibited.

- To modify this equipment.
- To use the equipment under any failure condition.
- To use the equipment without doing the daily and periodical check-up.
- To wipe the plastic covers with any disinfectant or detergent that contains organic solvent.
- To let a person on the chair who weighs over 300 lbs.
- To let two or more person on the chair.

1. OVERVIEW AND MAJOR COMPONENTS

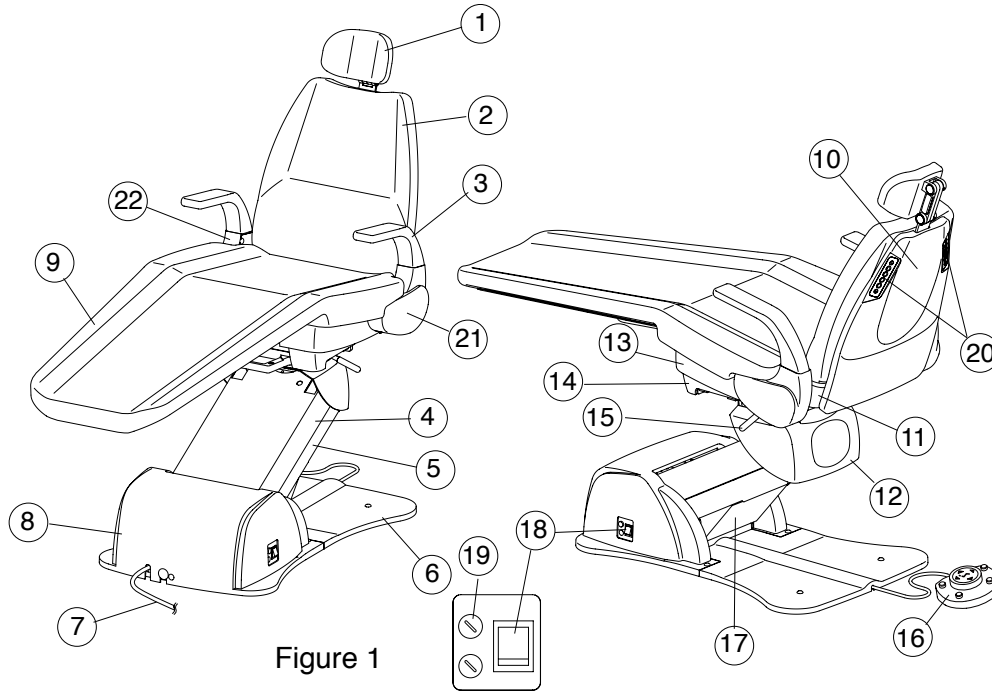

Figure 1

- | | | |
|-----------------------|---------------------------|-----------------------------|
| 1. Headrest Assembly | 9. Seat Cushion | 17. Sub Link Cover(Lower) |
| 2. Backrest Cushion | 10. Backrest Cover | 18. Main Power Switch |
| 3. Armrest | 11. Seat Back Support | 19. Fuse Holder |
| 4. Main Link Cover | 12. Dome Casting Cover | 20. Backrest Control Panels |
| 5. Sub Link Cover | 13. Tilt Cover | 21. Side Frame (Left) |
| 6. Base Cover | 14. Rotating Flange Cover | 22. Side Frame (Right) |
| 7. Power Supply Cable | 15. Rotation Lock Lever | |
| 8. Pump Cover | 16. Foot Control Ass'y | |

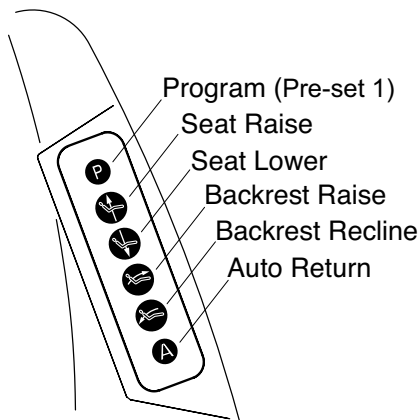

Figure 2
BACKREST CONTROL

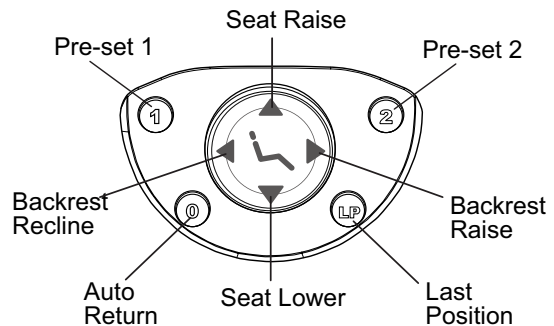
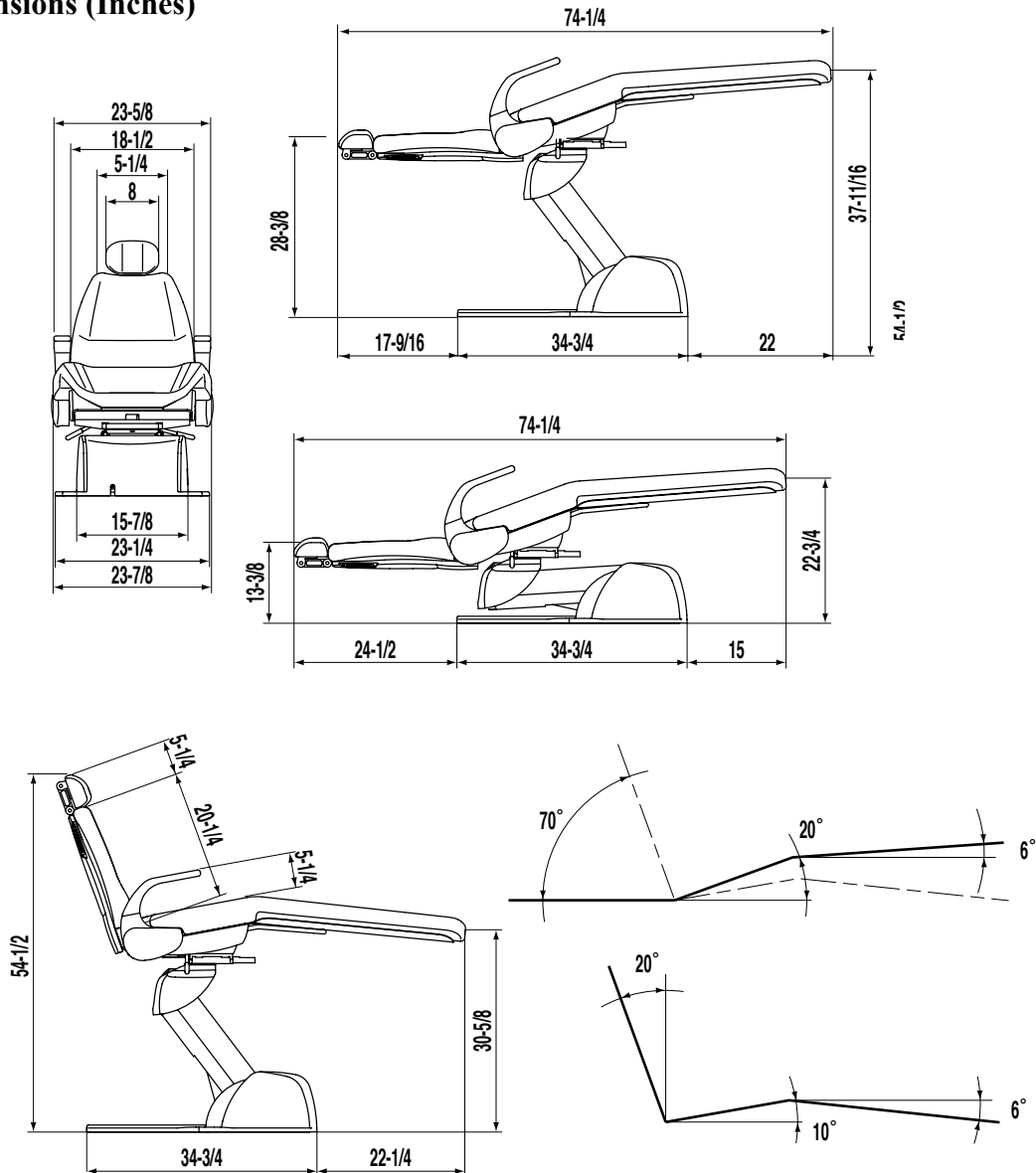

Figure 3
FOOT CONTROL

2. DIMENSION AND SPECIFICATIONS

2-1. Dimensions (Inches)



2-2. Specifications

- * Power sealed hydraulic system powered by 3.5 A motor pump
- * Base plate: 1/2" steel
- * Bearings at link points - low friction in steel jacket.
- * Steel seat cradle
- * Steel backrest support
- * Electrical requirements : AC120V/60Hz/3.7A
- * Fuse for power supply : 10A/125V (Current rating : 750A at 250VAC) Fast-blow
- * Fuse for relays : 1.25A/125V (Current rating : 750A at 250VAC) Fast-blow
- * Hospital grade plug
- * Base component housing formed from solid color acrylate styrene acrylonitrile (ASA ,V0)
- * All exposed ferrous parts covered with corrosion-resistant paint or plating
- * Weight: 381 lbs. (173 kg)

3. OPERATIONS

CAUTION

Before use

- Check connection of switches and make sure that the device functions properly.
- Make sure that grounding wire is connected.
- Make sure that cables are properly and perfectly connected.
- Be careful when you use the equipment combined with another, as it may lead to inadequate decision or danger.

Patient Entry

- Do not operate the chair until patient is fully seated. Patient head, back and feet must be in full contact with seat cushions. Patient hands must be placed on top of forward facing armrests or on their lap. All patients are at risk of potential injury if these precautions are not followed.
- Do not allow patient to sit on the headrest, armrest, backrest or the end of seat. Do not give too much load on the chair cushions. Failure to do so might lead to malfunction or an accident, such as fall from the chair or break of the device.

During use

- Do not use the chair longer than required for examination or treatment.
- Always watch the patient and the equipment to make sure nothing is wrong.
- If anything wrong is observed with the equipment or the patient, take a proper action, such as stopping the use of equipment as well as keeping the patient in safe.
- Keep an eye on the patient not to touch the equipment.
- Do not touch the patient and the fuse holder simultaneously.

After use

- Turn off the switch and pull of the power supply plug.
- Clean the equipment and get it ready for use.

3-1. Main Power Switch

- 1) Plug chair into 120VAC outlet.

CAUTION

To avoid the risk of electric shock, this equipment must only be connected to a supply mains with protective earth. Grounding reliability can only achieved when the equipment is connected to an equivalent receptacle marked HOSPITAL ONLY or HOSPITAL GRADE.

- 2) Turn on the main power switch located on the left side of the pump cover. A green lamp will illuminate.

CAUTION

Operate the Main Power Switch by hand only. Turn off the main switch after daily operation. Do not touch any switch with a wet hand, as it might cause electric shock.

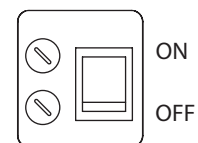

Fig.3-1 Main Switch

NOTE

Do not touch a switch on the foot control when Main Switch is turned on.

3-2. Controls

1) Seat Height Adjustments

- Raise the seat by pressing foot, backrest or touchpad control labeled with a chair symbol identified by an arrow pointing in the UP direction.
- Lower the seat by pressing foot, backrest or touchpad control labeled with a chair symbol identified by an arrow pointing in the DOWN direction.

Backrest Control



Foot Control



2) Backrest Adjustments

- Raise the backrest by pressing foot, backrest or touchpad control labeled with a chair symbol identified by an arrow pointing in the FORWARD direction.
- Lower the backrest by pressing foot, backrest or touchpad control labeled with a chair symbol identified by an arrow pointing in the RECLINE direction.



3) Programming a Seat Position

a. Preset Control

BEL-50 chair has two preset positions. (Pre-set 1 and Pre-set 2)

Momentarily depress (P) button on the backrest control or (1) button on the foot control, the chair will move to the preset-1 position automatically. (Preset-2 is operated by (2) button.)



b. Auto Return

Momentarily depress (A) button on the backrest control or (0) button on the foot control, the chair will return to the initial position. (The seat is fully lowered and the backrest is in the upright position.)



c. Last Position Memory

Momentarily depress (LP) button at the reclined backrest position (treatment position), the backrest will raise to the mouth rinsing position automatically.



Momentarily depress (LP) button again, the backrest will recline to the previous treatment position automatically.

Note : Seat height can not be changed by (LP) button.

4) Auto Mode Position Adjustment

Two preset positions can be set.

Set the seat and the backrest to the desired preset position by manual control switch.

Keep depressing pre-set 1 switch (P) or (1) until buzzer sounds (in about 3 seconds), then release it. The position is memorized for Preset-1.

Preset-2 can be memorized by depressing pre-set 2 switch as same procedures.

5) Mouth Rinsing Position Adjustment

Mouth rinsing position in last position memory movement can be adjusted. Set the backrest to the desired mouth rinsing position by manual control switch. Keep depressing last position memory switch (LP) until buzzer sounds (in about 3 seconds) and release it. This backrest position is then memorized as the mouth rinsing position.

3-3. Armrest Rotation, Seat Rotation, Cancellation, Headrest Adjustment

1) Armrest Rotation

Armrests rotate outward 180 degrees.



To avoid damage to armrests and chair mechanisms, be certain that armrests are not positioned over the backrest during backrest position adjustment.

2) Seat Rotation

Seat may be rotated 30 degrees to the right or left of center.

Seat position is locked or released using lever shown in Figure 1.

3) Cancellation

- a. Safety plate is provided below base link cover to stop motion of chair when object is accidentally caught underneath.
- b. Automatic motion activated either by automatic return switch or preset switch, can be cancelled at any time by depressing any control switches.

4) Headrest Adjustment

- a. Press down or pull up the headrest for height adjustment.
- b. Grab the headrest release lever on headrest mechanism.

⚠ CAUTION

Take care not to pinch the fingers with the headrest mechanism.

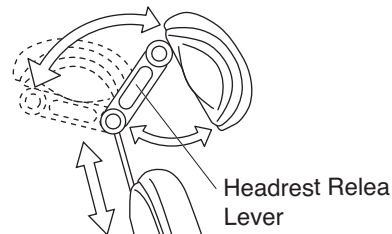

3-4. Positioning of Headrest

1. Seat patient upright and all of the way back on the chair.
2. Position the bottom of the headrest cushion so it is even with the occipital of the patient's head.

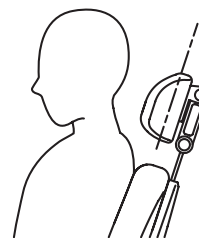

Viewing the lower arch

1. Using the latch release button (white), pivot the headrest cushion halfway toward the patient's head.
2. Have the patient lean back on the headrest.
3. Using the chair controls, place the patient in the desired operating position

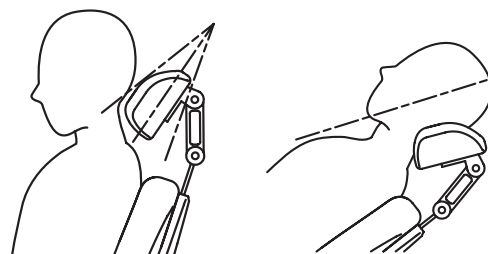

Viewing the upper arch

1. Lower the backrest and raise the base of the chair.
2. Slide the headrest in.
3. Support the patients head/headrest cushion while pressing latch release button.
4. Tilt the headrest cushion until the desired upper arch position is obtained.

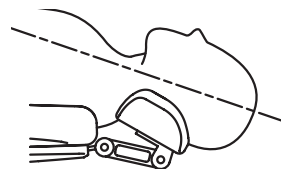

4. CARE AND MAINTENANCE

4-1. Cleaning and disinfection

CAUTION

Do not spray liquids directly onto chair surfaces.

In order to prevent damage to electrical components and systems, do not apply excess cleaning solution onto chair surfaces.

Routine Care

Clean plastic and upholstery surfaces regularly using a mild soap and water solution.

When cleaning, use a dampened cloth only, as excess cleaning solution can flow into the chair and cause permanent damage to electrical components.

Barrier Technique

Use of disposable barrier products should be the first choice for the protection of dental equipment. Disinfectants leave behind a surface residue that accumulates over time and eventually damages equipment and upholstery surfaces.

Chemical Disinfection

If a chemical disinfectant is to be used on chair or upholstery surfaces, contact the manufacturer of the disinfectant prior to use.

Obtain verification from the disinfectant manufacturer that their product will not damage the chair or upholstery surfaces.

Unacceptable Disinfectants

The following chemicals may damage equipment and upholstery:

- * Alcohol based solutions
- * Bleach
- * Phenol / Alcohol combinations
- * Foam spray products
- * Benzalkonium chloride solutions

Use with Caution

- * Water based phenolic disinfectants, following manufacturer's exact instructions for use.

NOTE

Warranty does not cover damage to equipment and upholstery caused by disinfectant solutions.

4-2 Storage and working lifetime

4-2-1 Storage

1. Keep the equipment away from water.
2. Keep in a circumstances safe from influence by temperature, humidity, wind, sun light, air containing salts and minerals.
3. Care about stability such as inclination, vibration and impact, including handling and transportation.
4. Do not keep the equipment in a place where chemicals are or where gas is emitted.

4-2-2 Lifetime

Provided that the recommended and authorized care and maintenance are correctly performed, the working lifetime of this equipment is 10 years from the date of initial shipment from the manufacturer.

4-3. Daily Check-up of functions by the end user

The end-user is responsible for daily check-up of the equipment. In the case end user does not do this, it is allowed that you outsource it to a technician authorized by us.

In order to assure safety use of this equipment, please carry out the following check-up in a frequency as indicated below.

No.	Item (Frequency)	How to check and diagnose	Influence of not doing check-up	Actions when any incompliance is found
1	Safety functions (Daily. Before opening office)	During pre-set movement or auto-return movement, press any key for chair operation and the chair should automatically stop.	Injury caused by movement of the chair during treatment or pinching with chair and other equipment or furniture.	Call to a technician of our authorized dealer.
2	Function of each switch (Daily. Before opening office)	Each switch for chair operation should work correctly.	Defect of movement may cause an accident.	Call to a technician of our authorized dealer.
3	Wiping off water (Daily. Before closing office)	Make sure that no water is left that were spilt during treatment.	Water will cause rust	Wipe off water with a soft and dry cloth.
4	Stain removal of external parts (Daily. Before closing office)	Visually make sure that no dust, chemical or other material is left on the chair.	Such chemicals will cause discoloration, deterioration and break of the plastics.	Thoroughly clean the chair following the cleaning instruction in this book, regardless the result of this check-up. For tough stains, use mild detergent solvency.
5	Main power switch (Daily. Before closing office)	Make sure that the main power switch is off	Accident or defect of the equipment	In the case the main power cannot be turned off, Call to a technician of our authorized dealer.
6	Moving parts (Weekly)	Make sure that the chair does not make any abnormal noise during automatic movement	Accident or defect of the equipment	Call to a technician of our authorized dealer.
7	Oil leakage (Weekly)	Make sure that there is no hydraulic oil on the floor or chair base leaking from the cylinder.	Defect of the equipment	Call to a technician of our authorized dealer.
8	Power supply cable (Monthly)	Power supply cable should not be abnormally bent, pinched or damaged, and the plug should be firmly inserted to the power outlet and not covered with dust.	Accident or defect of the equipment	Clean and rearrange the cable. For replacement, call to a technician of our authorized dealer.

4-4. Guideline for Periodical Check-up

- Some parts and components of the products are degraded or deteriorated depending on the frequency of use, so yearly check-up and maintenance, as well as replacement of consumable parts, are required.
- For check-up and repair, call a technician of our authorized dealer.

Parts and components that require periodical check-up

No.	Parts Description	Standard Lifetime
1	Headrest Mechanism	2 years
2	Electric wiring of moving parts	2 years
3	Switthes for operating equipment	2 years
4	Control PCBs	3 years
5	Hydraulic cylinder and related parts	5 years

Consumables

No.	Parts Description
1	Power supply cord
2	Cusions and Upholsteries
3	Base Cover
4	Pump Cover

4-5 Disposal

- This is not an infecious device, but prior to disposal make sure that no parts of the device is infected.
- Follow the federal, state and local regulations for disposal.

NOTE

This equipment should be installed by a professional technician(s) of our company or a company authorized by us. Follow the installation manual enclosed with this manual for details of installation.

Company or person authorized to install this equipment

Name :

Address :



BELMONT EQUIPMENT, Division of Takara Belmont, USA, Inc.

101 Belmont Drive Somerset, New Jersey 08873 U.S.A. TEL.:(732)469-5000 / (800)223-1192 Fax.:(732)356-1035

www.belmontequip.com

TAKARA CO, CANADA LTD.

2076 S. Sheridan Way, Mississauga, Ont., L5J2M4, Can. TEL.:(905)822-2755 Fax.:(905)822-6203

www.takarabelmont.ca



TAKARA BELMONT CORPORATION (Manufacturer)

2-1-1, Higashi-shinsaibashi, Chuo-ku, Osaka, Japan TEL.: 81-6-6213-5945 FAX.: 81-6-6212-3680